

21.5" All-Aluminum Touch Monitor

STRENGTH WITHOUT THE BULK.

The Slimmest 21.5" Touch Monitor in the Industry.



Features

- ◆ **Elegant Design** that seamlessly blends into any retail or industrial setting.
- ◆ **Optical Bonding** ensures superior visibility without water condensations.
- ◆ **Ultra-Thin Borders** provide a broader, cleaner viewing experience.
- ◆ **Ultra-Slim Profile** — Just 10mm at its thinnest.
- ◆ **USB Type-C** — Video, audio, and data transmission via a single cable.
- ◆ **Robust All-Aluminum** housing built to withstand demanding environments.
- ◆ **Full HD 1920x1080 Resolution** delivers the clarity needed for critical tasks.
- ◆ **IP65-Rated** front bezel offers excellent protection against dust and water.

ID Appearance



Dimensions

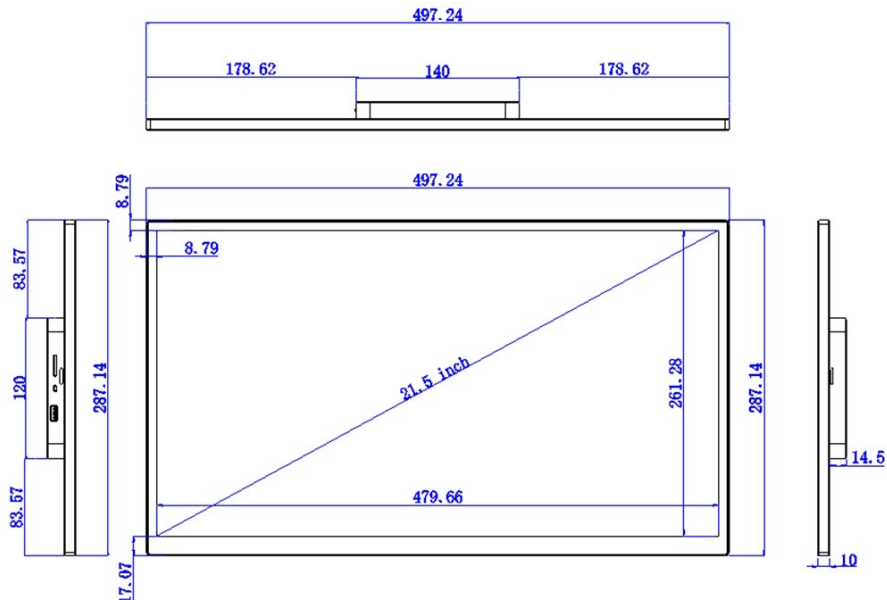
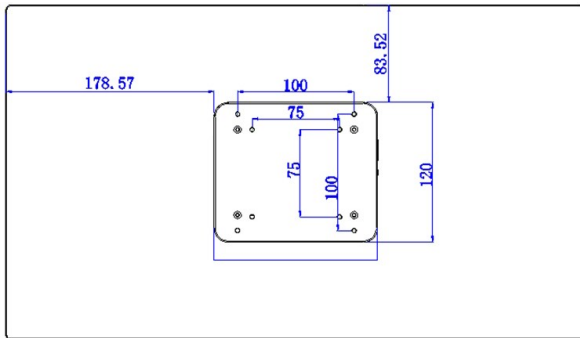

Technical Specification

Model		A215
LCD	Size	21.5"
	Resolution	1920 x 1080 FHD
	Brightness	300 cd/m ² (Typ.)
	Contrast Ratio (Typ.)	3000:1
	Response Time (Typ.)	20ms
	Viewing Angles (H/V)	178° / 178°
	MTBF	30,000 hrs (Min.)
Touch Screen	Type	10 Points Projected Capacitive
I/O		1 x USB-C (DP Alternate Mode w/o PD)
		1 x HDMI
		1 x DP
		1 x USB 2.0 (downstream)
		1 x Audio-Out (3.5mm)
		1 x DC-IN (12V/3A)
Internal Speaker		2 x 1Watt
Power		External Power Adapter 12V/3A
Environmental	Operating Temp.	0°C ~ 40°C
	Storage Temp.	-20°C ~ 60°C
	Operating Humidity	20% ~ 85% RH non-condensing
	Storage Humidity	20% ~ 85% RH non-condensing
Housing		Aluminum Alloy
Dimension (W x D x H)		497.2 * 260.3 * 24.5 mm
Weight (N.W./G.W.)		2.4kgs / 3.8kgs
Wall Mount		VESA 75*75mm, 100*100mm

* Specification is subject to change without prior notice.