



**M Series | M215BX |**

## 21.5" Metal Industrial Touch Monitor



### Key Features

1. Rimless metal bezel, Ergonomic enclosure design, Mechanical design for additional equipment installation.
2. Front bezel meet **IP65** standard.
3. Additional "**External (OSD) control key pad**" for service purpose.(option)
4. 21.5" diagonal screen with native resolution 1920 x 1080.
5. 16:9 aspect ratio for both Portrait and Landscape available.
6. VESA 100 x 100 wall mounting standard.
7. 10-Points projected capacitive touch panel, EETI multi-touch technology. Support EETI **active stylus pen**.
8. Touch panel supports higher sensitivity, allows operation even with **wearing gloves**. Such as cotton gloves, 3M comfortable grip gloves and latex gloves.(by request)
9. User friendly OSD control buttons with keys lockable.
10. **Side mounted** design with metal brackets.(option)
11. Attached **cable organizer** to keep cables well organized.(option)

### Application

Factory Automation / Heavy Industry / Medical / Public Transportation

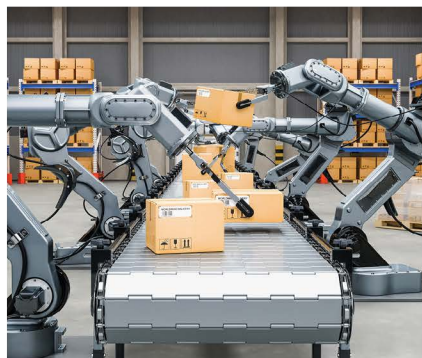

Specification	
Active Screen Size	21.5 inch
Aspect Ratio	16:9
Resolution	1920×1080
Panel Brightness	250nits (Typ.)
Contrast Ratio	1000:1 (Typ.)
Response Time	22ms (Typ.)
MTBF	50,000hrs (Min.)
Touch Type	Projected Capacitive Touch (PCAP)
Connectivity	VGA×1, HDMI×1, DisplayPort×1, Audio line in×1, USB type B for touch
	D-SUB-9 x 1 (for External Function Key)
Audio Input	3.5mm phone jack
Audio Output	Internal speaker, 3W×2
Function Key	POWER, AUTO, UP, DOWN, MENU
OSD Language	English, 繁中, 簡中
Adaptor Power Input	AC 100-240V 1A, 50-60Hz
Adaptor Power Output	DC 12V 3A
Power Consumption	TBD
Operating Temperature	0°C~50°C
Operating Humidity	10% to 85% (non-condensing)
Storage Temperature	-20°C~60°C
Storage Humidity	5% to 80% (non-condensing)
VESA Compatibility	100×100 mm
Dimensions (W×H×D)	Physical 524×316×46mm
Weight	TBD

\* Specification is subject to change without prior notice.

**I/O indication**

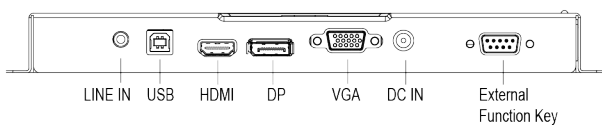

**External Control key pad (option)**

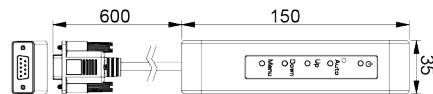

**On Board Control Key Pad**

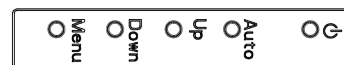

**Dimension (unit: mm)**

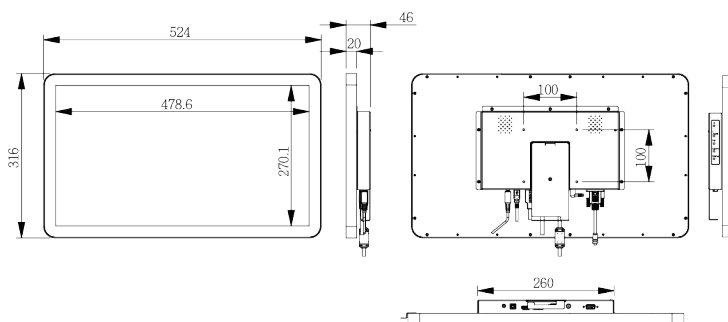

**Side Mount Kit and Cable Organizer (option)**

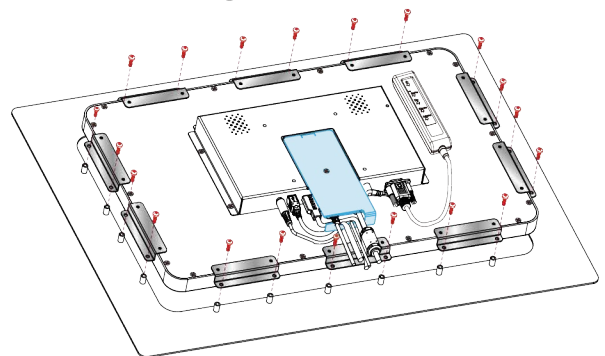

For more information on this and other Phistek products, please visit our website at:

[www.phistek.com](http://www.phistek.com)    [sales@phistek.com](mailto:sales@phistek.com)



**PHiStek**  
Display Solution Provider